

conveyors & elevators

Firstgrade produce several ranges of conveyors and elevators to suit different applications. The 220 series are a range of sliding bed conveyors. They are available in widths from 600mm to 2100mm, and lengths up to 10 metres. The 350 series use 4" troughing rollers, and are ideally suited to longer conveyor lengths.

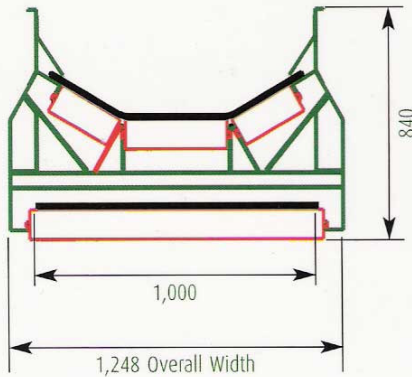

series 350

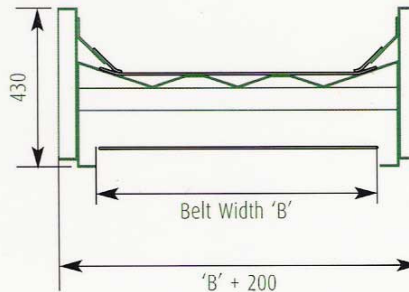

series 220

features

- Heavy Duty 3 ply rubber belts
- Low maintenance electric motor and gearbox
- Simple reliable construction

options

- Cleated belts for elevation
- Belt scrapers for belt cleaning
- Weatherproof covers
- Mounting legs
- Automatic greasing

applications

- Construction & Demolition Waste
- Municipal Solid Waste
- Compost
- Skip Waste

design, build and install

All of firstgrade's recycling machinery is designed and built here in the UK, using the latest Computer Aided Design technology. This, together with our engineering expertise, gives us the flexibility to produce high specification systems to suit individual requirements.

other products

- Vibrating Feeders
- Trommel Screens
- Vibrating Screens
- Picking Stations
- Tipping Skips

capacity				options
Series	Width	Belt Speed	Capacity*	
350	1000	0.8 m/s	350 m ³ /ph	Cleated belts for elevation
220	750	0.6 m/s	65 m ³ /ph	Belt scrapers for belt cleaning
220	1000	0.6 m/s	105 m ³ /ph	Weatherproof covers
220	1500	0.6 m/s	278 m ³ /ph	Mounting legs
220	2100	0.6 m/s	460 m ³ /ph	Automatic greasing
* In horizontal position				

Firstgrade Recycling Systems Ltd
D'Urbans
Framlingham
Suffolk
IP13 9RP

t 01728 724365
f 01728 724291
e sales@first-grade.co.uk
w first-grade.co.uk